

OPTIONAL ACCESS COVERS

for SEPTIC TANKS, HOLDING TANKS, SEWAGE PUMPING TANKS and WATER RESERVOIRS

Cast Iron Manhole Frame and Cover
Type A or B - OPSD Ref. 401.01

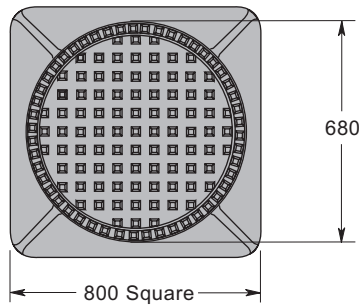

Cast Into Roof

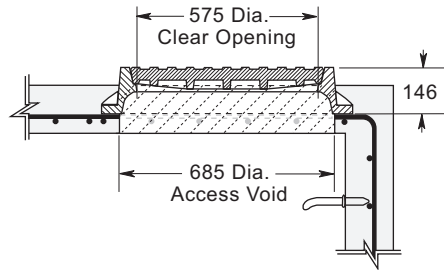

Set Over Access Opening

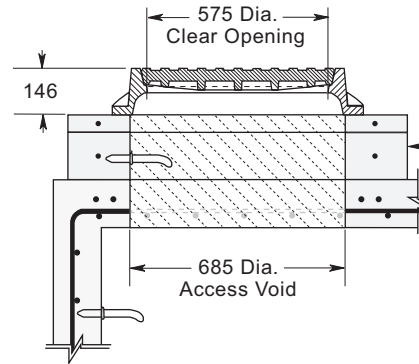

Grade Adjustment Rings:
Available in heights of 50, 75, 150, 300 & 600 mm

Concrete Hatches

Tapered Type

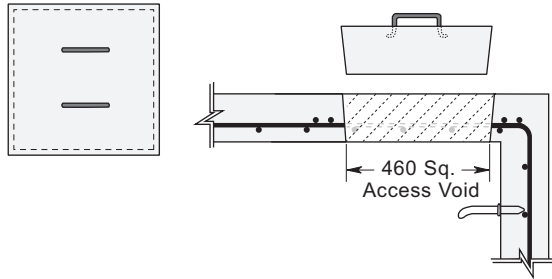

Large Diameter Type

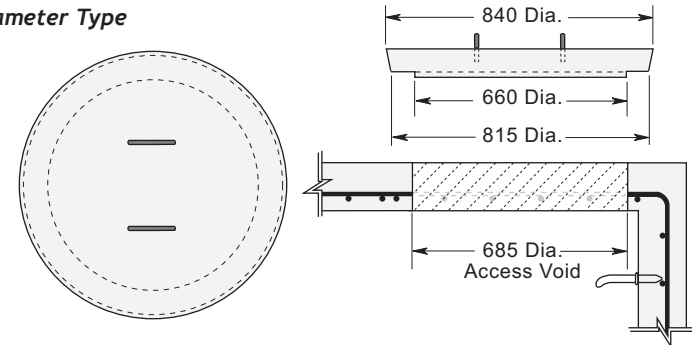

Hinged and Lockable, Galvanized Steel or Aluminum Frames and Covers

Drip Proof Type Cast Into Roof

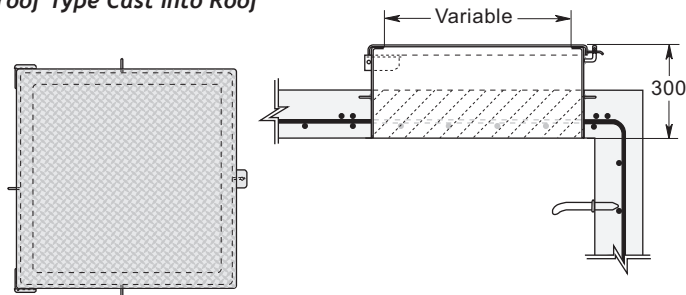

Flush Type Cast Into Roof

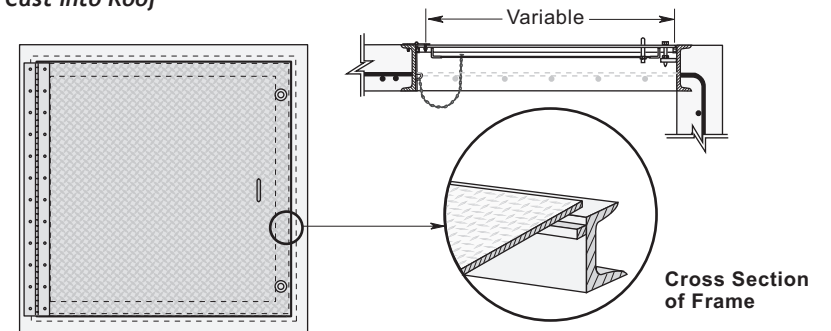

Also Available Are Many Types of Custom Built Covers and Grates Designed For Specific Requirements

Dimensions in mm
N.T.S.

WILKINSON HEAVY PRECAST LIMITED

DUNDAS, ONTARIO

905-628-5611

www.wilkinsonheavyprecast.com