

3000 LITRE PRECAST WASTEWATER HOLDING TANK MODEL H3H

WILKINSON HEAVY PRECAST LIMITED

DUNDAS, ONTARIO

905-628-5611

www.wilkinsonheavyprecast.com

CLASS H - HEAVY CONSTRUCTION

CONSTRUCTION DETAILS *

Concrete: 35 MPa at 28 Days, 5 to 8% Air Entrainment.

Reinforcing: 10 M bars at 300 mm centres each way in walls.
10 M bars at 150 mm centres each way in roof and floor.
Eight extra 15 M bars around roof access opening.
Minimum cover over reinforcing steel - 25 mm.

Weight: Top Section 2220 kg
Bottom Section 4030 kg
Total 6250 kg

Actual Capacity: 1440 Litres Per Vertical Metre.
3283 Litres to Underside of Roof.

NOTES

1. Large 685 mm diameter roof access openings facilitate tank maintenance. Unless otherwise specified/ordered this tank will be shipped with 840 mm diameter concrete hatch covers. Please note that each cover weighs approximately 125 kg and must be handled only with suitable mechanical lifting equipment. Please see Access Riser section for available options.
2. Close tolerance shiplap joint and fibrous mastic sealant ensures a solid watertight seal. Primer and Mastic Band are supplied with each tank for application to the external surface of the tank over the joint between sections. This band is to be applied by the installing contractor.
3. Number, size and positioning of wall penetrations to customer's specification.
4. Top section lifting points four places.
5. Bottom Section lifting points in walls four places.

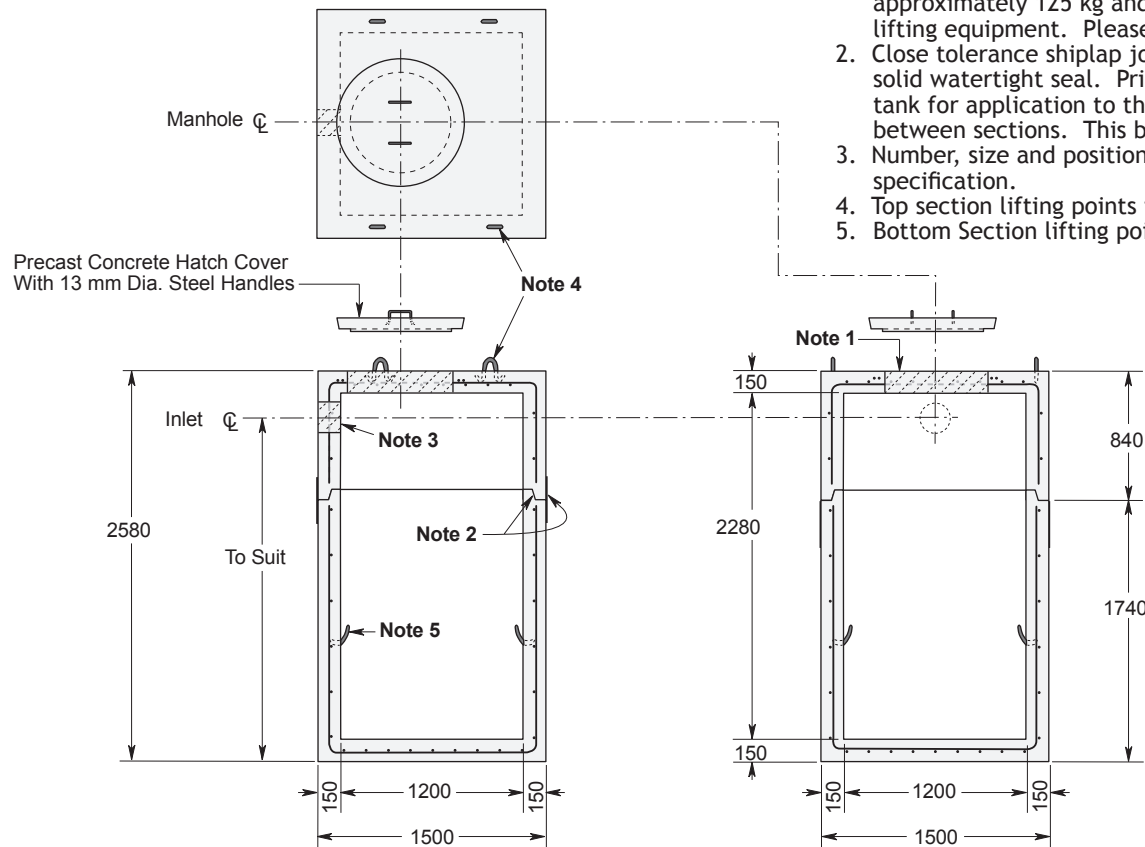

* Commensurate with a 3 Metre burial over the top slab in firm soil and under an area of vehicular traffic.

For recommended installation procedures refer to Wilkinson Installation Guidelines.

WARNING ! IMPROPER INSTALLATION ESPECIALLY IN UNSTABLE SOILS CAN RESULT IN THE STRUCTURAL FAILURE OF THIS PRODUCT