

ROUND MANHOLE SECTIONS

WILKINSON HEAVY PRECAST LIMITED

DUNDAS, ONTARIO

905-628-5611

www.wilkinsonheavyprecast.com

RISER SECTIONS - 1200, 1500, 1800, 2400 & 3000 mm Manholes
OPSD Ref. - 701.03, 701.04, 701.05 and 701.06

CONSTRUCTION DETAILS

Concrete: 35 MPa at 28 Days, 5 to 8% Air Entrainment.

Reinforcing: Refer to Dimension Chart

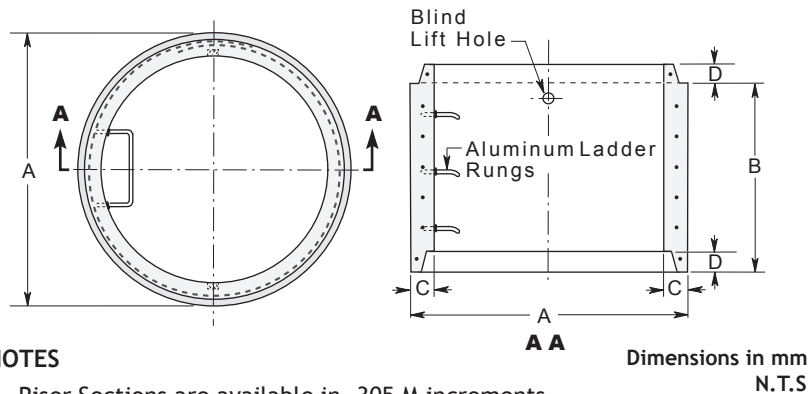

NOTES

- Riser Sections are available in .305 M increments.
- 1200 mm Diameter manhole is also available with a 200 mm wall thickness.

DIMENSION CHART		METRIC MEASURE IN MILLIMETERS				
Nominal Inside Diameter		1200	1500	1800	2400	3000
A. Outside Diameter		1470	1830	2185	2895	3555
B. Height		.3 to 1.83 metres Note 1	.3 to 2.1 metres Note 1	.3 to 1.83 metres Note 1	.3 to 2.1 metres Note 1	.6 to 2.74 metres Note 1
C. Wall Thickness		125	150	180	230	255
D. Joint Height		100	120	120	125	165
Minimum Reinforcing	Area of Circumferential Steel/Vertical M	250 sq. mm	315 sq. mm	378 sq. mm	507 sq. mm	630 sq. mm
Weight - Kgs Per Vertical Metre		1300	1960	2730	4650	6415

FLAT CAPS - 1200, 1500, 1800, 2400 & 3000 mm Manholes
OPSD Ref. - 701.03, 701.04, 701.05 and 701.06

CONSTRUCTION DETAILS

Concrete: 35 MPa at 28 Days, 5 to 8% Air Entrainment.

Reinforcing: As per applicable OPSD Spec.

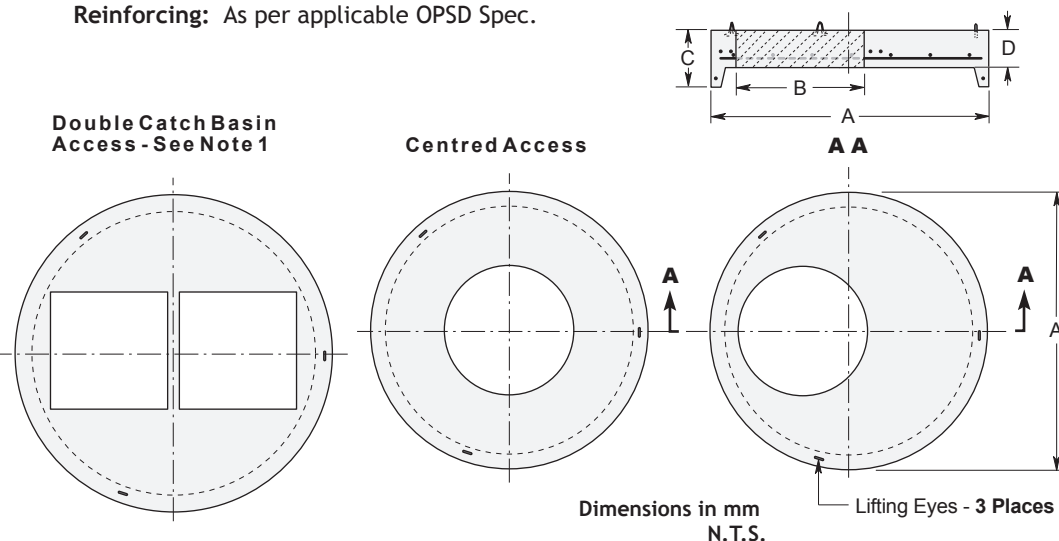

DIMENSION CHART		METRIC MEASURE IN MILLIMETERS				
Nominal Manhole I. D.		1200	1500	1800	2400	3000
A. Outside Diameter		1470	1830	2185	2895	3555
B. Access Diameter		685	685	685	685	685
C. Total Thickness		305	425	425	430	470
D. Top Thickness		200	305	305	305	305
Weight In kgs		750	1900	2800	5000	7750

NOTES

- Twin Inlet flat top will accommodate two catch basin frames and grates. Available only in 1500 mm and larger manholes.

WARNING ! IMPROPER INSTALLATION ESPECIALLY IN UNSTABLE SOILS CAN RESULT IN THE STRUCTURAL FAILURE OF THIS PRODUCT