

28,500 LITRE PRECAST WASTEWATER HOLDING TANK MODEL H28.5S

WILKINSON HEAVY PRECAST LIMITED

DUNDAS, ONTARIO

905-628-5611

www.wilkinsonheavyprecast.com

CONSTRUCTION DETAILS *

Concrete: 35 MPa at 28 Days, 5 to 8% Air Entrainment.

Reinforcing: 10 M bars at 200 mm centres each way in roof, walls and floor; horizontally in top section partition.
Four extra 15 M bars around roof access opening.
Minimum cover over reinforcing steel - 25 mm.

Weight: Top Section 10,472 kg
Bottom Section 12,016 kg
Total 22,488 kg

Actual Capacity: 12,378 Litres Per Vertical Metre.
28,469 Litres to Underside of Roof Slab.

NOTES

1. Large 685 mm diameter roof access openings facilitate tank maintenance. Unless otherwise specified/ordered this tank will be shipped with 840 mm diameter concrete hatch covers. Please note that each cover weighs approximately 125 kg and must be handled only with suitable mechanical lifting equipment. See Access Riser section for available options.
2. Close tolerance of tongue and groove joint and fibrous mastic sealant ensures a solid structural and water-tight seal. Primer and Mastic Band are supplied with each tank for application to the external surface of the tank over the joint between the tank sections. This band is to be applied by the installing contractor.
3. Flexible watertight pipe connectors four places to accommodate 100 mm diameter PVC pipe. Size and position of inlet void can be modified at customer's request. Consult with the factory as to how this will affect the liquid capacity of this tank.
4. Top section lifting points four places.
5. Bottom section lifting points four places.
6. The partition is cast monolithically with the walls and horizontal slab of top section.
7. Knee wall each side of bottom section is cast monolithically with the walls and horizontal slab.

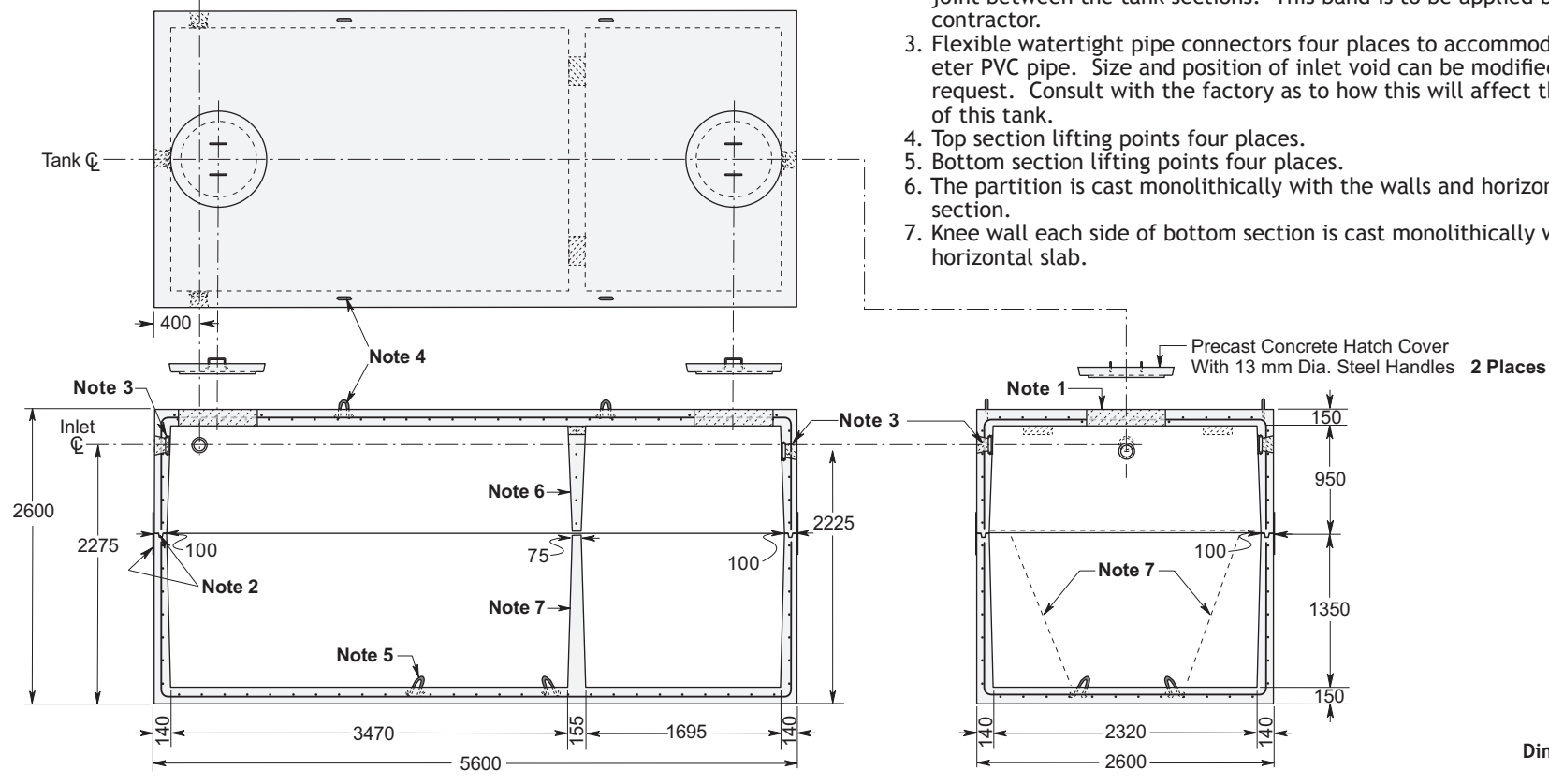

Dimensions in mm
N.T.S.

* Commensurate with a 1.2 Metre burial over the top slab in firm soil away from any area of vehicular traffic.

For recommended installation procedures refer to Wilkinson Installation Guidelines and Lifting and Assembly Instructions.

WARNING ! IMPROPER INSTALLATION ESPECIALLY IN UNSTABLE SOILS CAN RESULT IN THE STRUCTURAL FAILURE OF THIS PRODUCT