

# 45,000 LITRE TWO COMPARTMENT PRECAST SEPTIC TANK MODEL S45S

WILKINSON HEAVY PRECAST LIMITED

DUNDAS, ONTARIO

905-628-5611

www.wilkinsonheavyprecast.com

## CONSTRUCTION DETAILS \*

**Concrete:** 35 MPa at 28 Days, 5 to 8% Air Entrainment.

**Reinforcing:** 20 M bars at 300 mm centres each way in walls, roof and floor; horizontally in partition.  
Eight extra 15 M bars around each roof access opening.  
Minimum cover over reinforcing steel - 25 mm.

**Weight:** Top Section 20,000 kg  
Bottom Section 20,000 kg  
Total 40,000 kg

**Actual Capacity:** 18,785 Litres Per Vertical Metre.  
49,400 Litres to Underside of Roof.  
45,365 Litres to Invert of Outlet.

## NOTES

1. Large 685 mm diameter roof access openings facilitate tank and filter maintenance. Please note that each cover weighs approximately 125 kg and must be handled only with suitable mechanical lifting equipment. Access extensions may be required to meet Ontario Building Code requirements. See Access Riser section for available options.
2. Close tolerance of tongue and groove joint and fibrous mastic sealant ensures a solid structural and watertight seal. Primer and Mastic Band are supplied with each tank for application to the external surface of the tank over the joint between sections. This band is to be applied by the installing contractor.
3. Flexible watertight inlet/outlet pipe connector in each end wall accommodates 100 mm diameter PVC pipe. Size and position of inlet and outlet void can be modified at customer's request. Consult with the factory as to how this will affect the liquid capacity of this tank.
4. Inlet baffle is 100 mm PVC 'TY' fitting. It is supplied loose and meant to be cemented by the contractor to the inlet pipe.
5. NSF certified effluent filter for flow rates up to 38,000 litres per day. Note that the Ontario Building Code requires an effluent filter be accessible at grade. See Access Riser section for available options.
6. Stainless steel bracket supports effluent filter firmly in position to prevent damage or dislocation during pumping and maintenance operations.
7. 150 mm diameter partition flow throughs in four places evenly spaced across the partition.
8. The partition is cast monolithically with the walls and horizontal slab of each section.
9. Top section/bottom section lifting points four places.

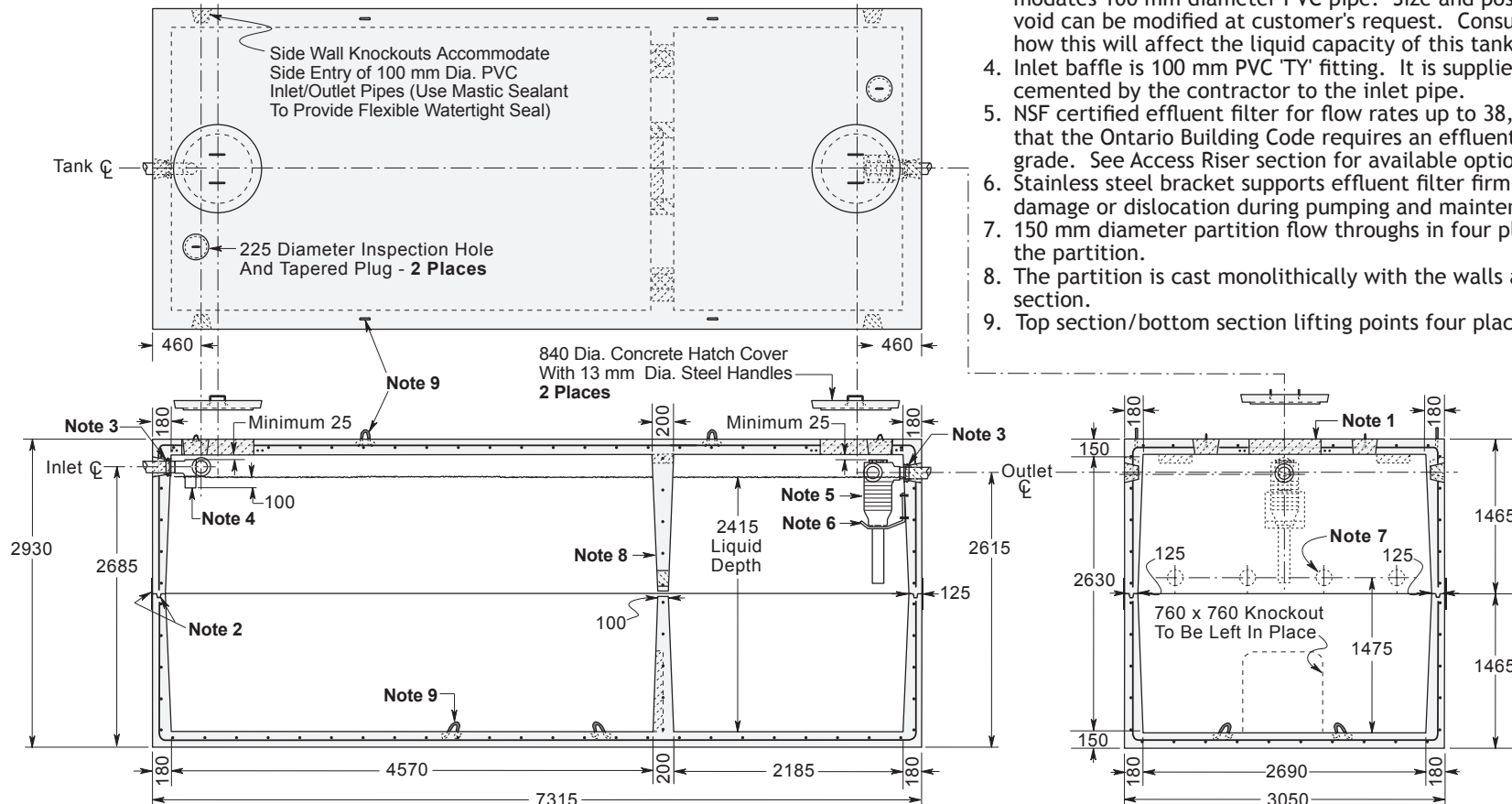

\* Commensurate with a 1.2 Metre burial over the top slab in firm soil away from any area of vehicular traffic.

For recommended installation procedures refer to Wilkinson Installation Guidelines and Lifting and Assembly Instructions.

**WARNING ! IMPROPER INSTALLATION ESPECIALLY IN UNSTABLE SOILS CAN RESULT IN THE STRUCTURAL FAILURE OF THIS PRODUCT**