

PRECAST UTILITY MANHOLE MODEL U73

WILKINSON HEAVY PRECAST LIMITED

DUNDAS, ONTARIO

905-628-5611

www.wilkinsonheavyprecast.com

CONSTRUCTION DETAILS *

Concrete: 35 MPa at 28 Days, 5 to 8% Air Entrainment. Precast concrete materials and construction conforms with CSA A23.4-00

Reinforcing: 15 M bars at 150 mm centres each way in roof, walls and floor. 12 extra 15 M Bars around roof access opening. Minimum cover over reinforcing steel - 25 mm.

Weight: Top Section 33,000 kg
Bottom Section 33,000 kg
Total Shipping Weight 66,000 kg (Excluding Riser)

NOTES

1. Close tolerance of tongue and groove joint and fibrous mastic sealant ensures a solid structural and watertight seal. Primer and Mastic Band are supplied with each tank for application to the external surface of the tank over the joint between sections. This band is to be applied by the installing contractor.
2. Number, size and positioning of wall penetrations to customer's specification.
3. Top section lifting points four places.
4. Bottom section lifting points four places.

Optional Appurtenances Shown On This Drawing:

5. Typical 1.5 M square Access Riser, with galvanized steel or aluminum hinged drip proof cover. Many other types of access risers and hatch covers are available.
6. Aluminum or galvanized steel ladder supplied loose for installation by contractor.
7. Mechanical connections 4 places between sections.

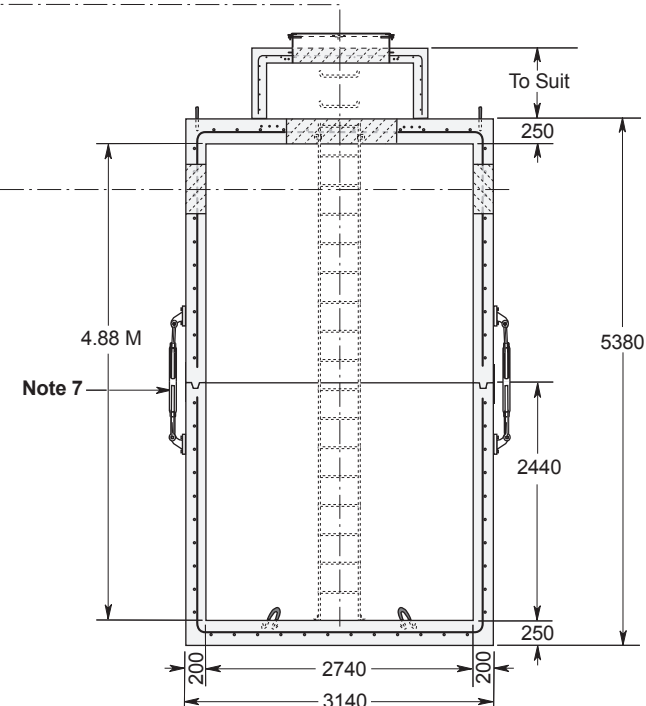
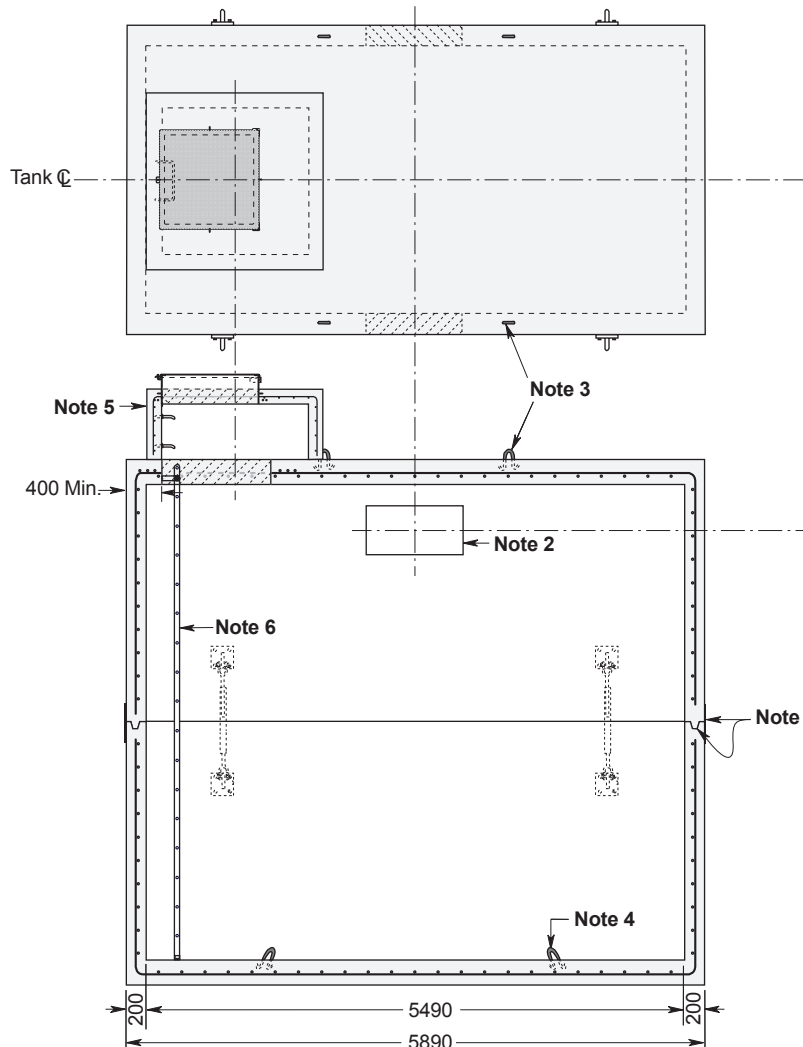

Dimensions in mm
N.T.S.

* Commensurate with a 2 Metre burial over the top slab in firm soil under an area of vehicular traffic.

For recommended installation procedures refer to Wilkinson Installation Guidelines and Lifting and Assembly Instructions.