

**PRECAST GARAGE CATCH BASIN MODEL CB120**

**460 MM SQUARE - 520 MM HIGH**

**CONSTRUCTION DETAILS**

Concrete: 35 MPa at 28 Days, 5 to 8% Air Entrainment.

Weight: 180 kg

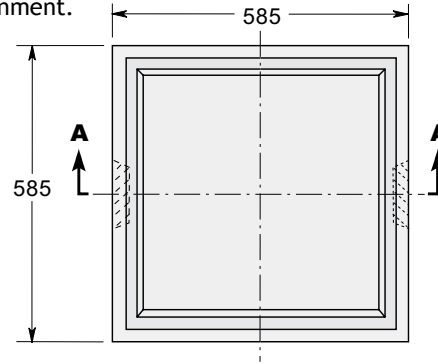

Inlet Knockout To Accommodate 100 mm PVC Pipe

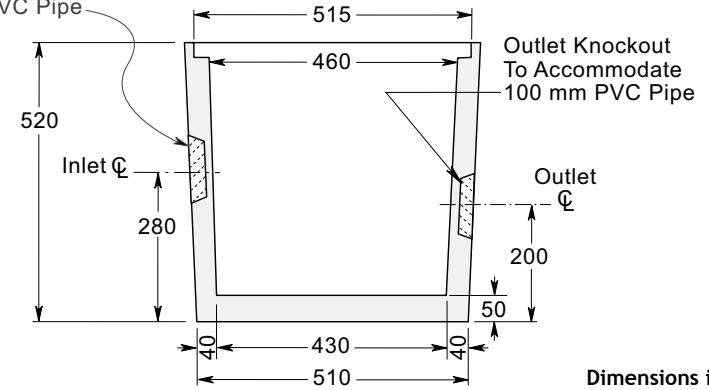

Dimensions in mm  
N.T.S.

**PRECAST GARAGE CATCH BASIN MODEL CB140**

**460 MM SQUARE - 1015 MM HIGH**

**CONSTRUCTION DETAILS**

Concrete: 35 MPa at 28 Days, 5 to 8% Air Entrainment.

Weight: 320 kg

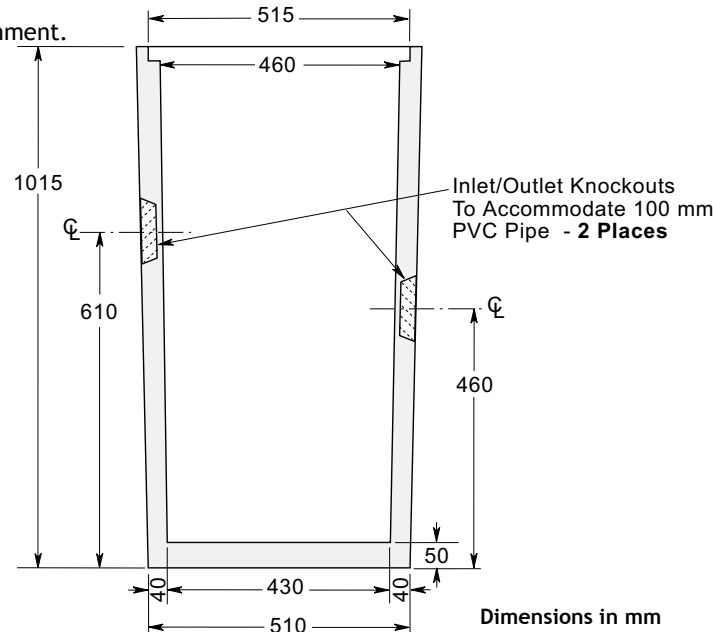
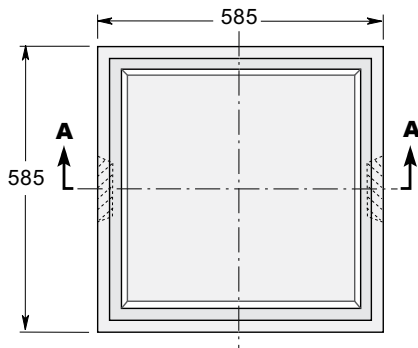

Dimensions in mm  
N.T.S.

**CAST IRON GRATE**  
For Models CB120 & CB140

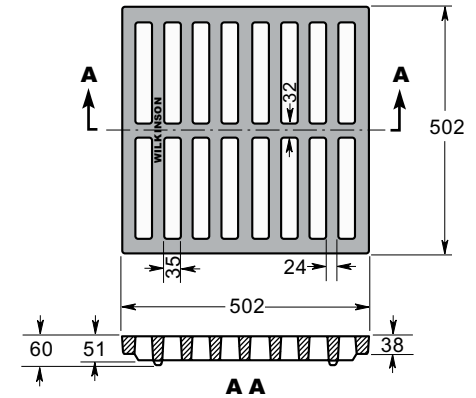

Dimensions in mm  
N.T.S.

**NOTES**

- Either catch basin can be supplied with or without cast iron grate.
- Weight of grate - 39 kg.

Dimensions in mm  
N.T.S.

For recommended installation procedures refer to Wilkinson [Installation Guidelines](#).

