

RISERS & ACCESS COVERS FOR INTERCEPTORS

WILKINSON HEAVY PRECAST LIMITED

DUNDAS, ONTARIO

905-628-5611

www.wilkinsonheavyprecast.com

for **MODELS 230 (Formerly Model 100) and 575 (Formerly Model 260)**

Precast Concrete Access Extension

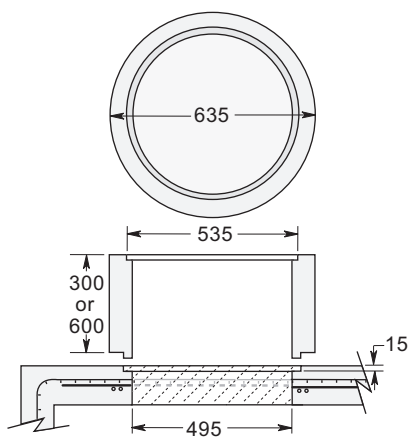

Cast Iron Frame and Gasketed Bolt Down Cover

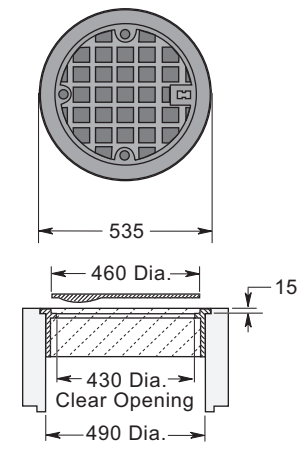

Precast Concrete Hatch Cover

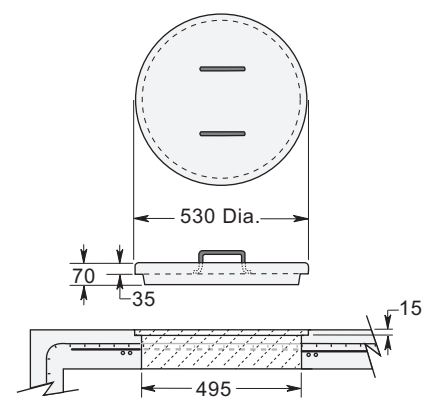

Accepts Precast Concrete Hatch Cover or Cast Iron Frame and Gasketed Bolt Down Cover.

for **MODELS 7 and 1075 (Formerly MODEL 1300)**

Precast Concrete Access Extension

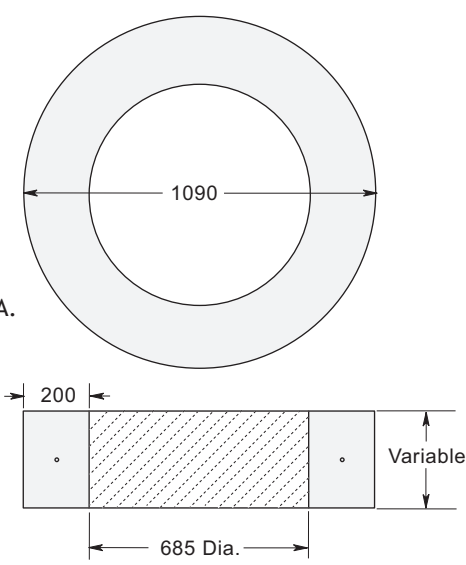

Bolted and Gasketed Cast Iron Frame and Cover - OPSD Ref. - 401.03
See Page For Detail.

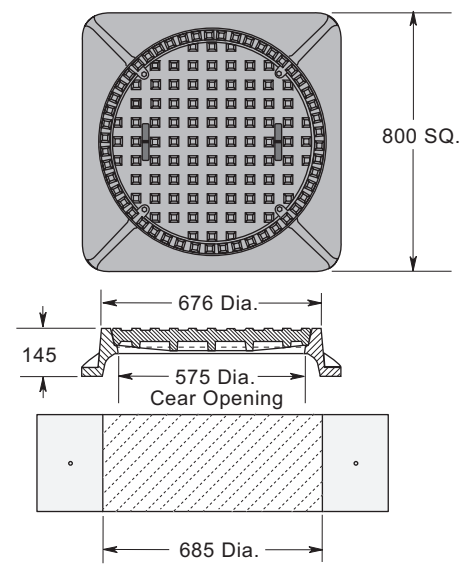

Precast Concrete Hatch Cover

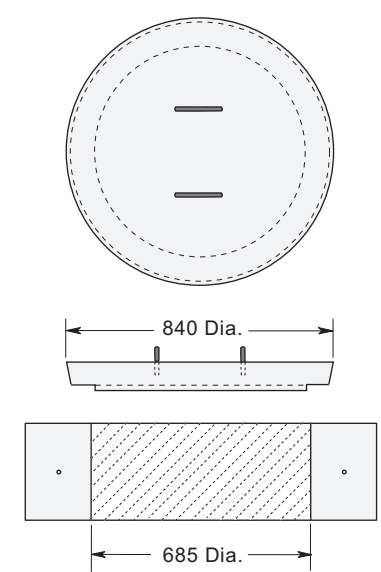

Accepts Precast Concrete Hatch Cover or Bolted and Gasketed Cast Iron Frame and Cover OPSD Ref. 401.03.

Other Options:

- Standard Closed Pattern Frame and Cover OPSD Ref. 401.01 Typ A.
- Locking Cover OPSD Ref. 401.060.

Dimensions in mm
N.T.S.