

# 8000 LITRE PRECAST WASTEWATER HOLDING TANK MODEL H8H

WILKINSON HEAVY PRECAST LIMITED

DUNDAS, ONTARIO

905-628-5611

www.wilkinsonheavyprecast.com

## CLASS H - HEAVY CONSTRUCTION CONSTRUCTION DETAILS \*

**Concrete:** 35 MPa at 28 Days, 5 to 8% Air Entrainment.

**Reinforcing:** 10 M bars at 300 mm centres each way in walls.  
10 M bars at 150 mm centres each way in roof and floor.  
Eight extra 15 M bars around roof access opening.  
Minimum cover over reinforcing steel - 25 mm.

**Weight:** Top Section 7195 kg  
Bottom Section 7195 kg  
Total 14,390 kg

**Actual Capacity:** 4000 Litres Per Vertical Metre.  
8000 Litres to Underside of Roof Slab.

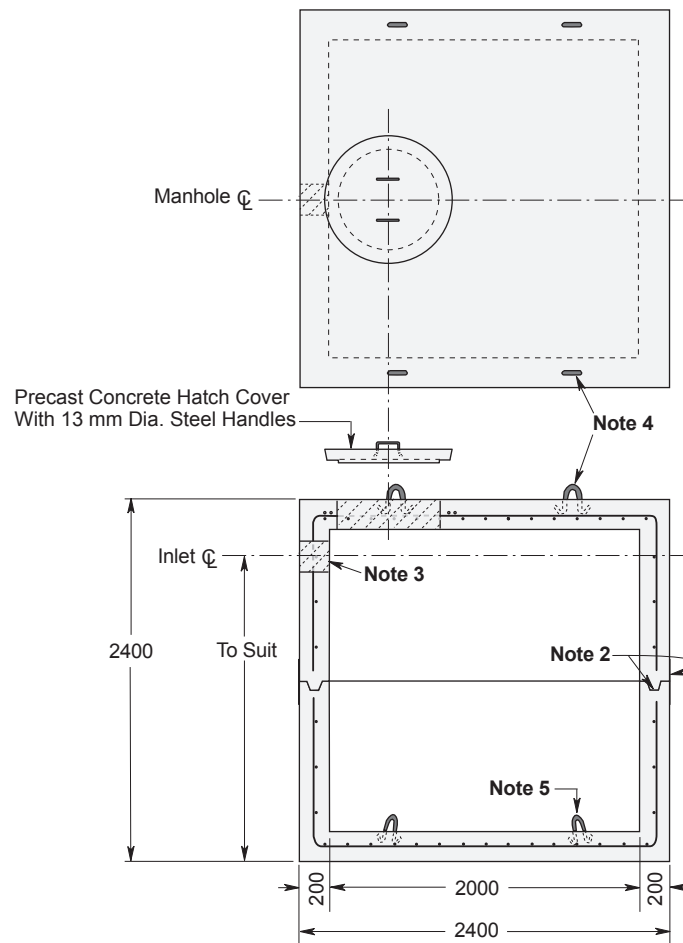

## NOTES

1. Large 685 mm diameter roof access openings facilitate tank maintenance. Unless otherwise specified/ordered this tank will be shipped with 840 mm diameter concrete hatch covers. Please note that each cover weighs approximately 125 kg and must be handled only with suitable mechanical lifting equipment. Please see Access Riser section for available options.
2. Close tolerance shiplap joint and fibrous mastic sealant ensures a solid watertight seal. Primer and Mastic Band are supplied with each tank for application to the external surface of the tank over the joint between sections. This band is to be applied by the installing contractor.
3. Number, size and positioning of wall penetrations to customer's specification.
4. Top section lifting points four places.
5. Bottom Section lifting points four places.

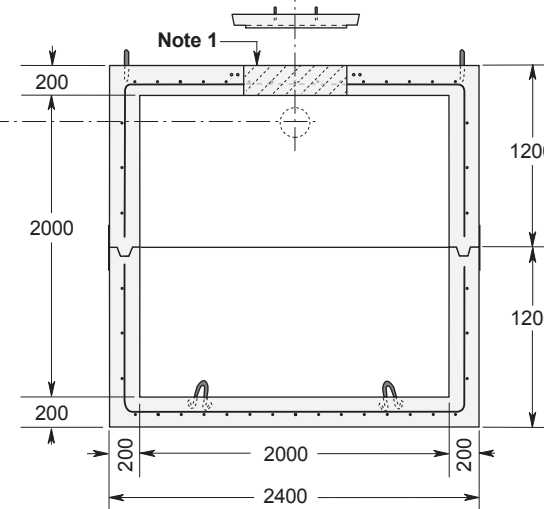

Dimensions in mm  
N.T.S.

\* Commensurate with a 3 Metre burial over the top slab in firm soil and under an area of vehicular traffic.

For recommended installation procedures refer to Wilkinson Installation Guidelines and Lifting and Assembly Instructions.

**WARNING ! IMPROPER INSTALLATION ESPECIALLY IN UNSTABLE SOILS CAN RESULT IN THE STRUCTURAL FAILURE OF THIS PRODUCT**