

20,000 LITRE TWO COMPARTMENT PRECAST SEPTIC TANK MODEL S20HL

WILKINSON HEAVY PRECAST LIMITED

DUNDAS, ONTARIO

1-800-263-8503

LOW PROFILE CLASS H - HEAVY CONSTRUCTION

CONSTRUCTION DETAILS *

Concrete: 35 MPa at 28 Days, 5 to 8% Air Entrainment.

Reinforcing: 20 M bars at 300 mm centres each way in walls and floor; horizontally in partition.
2 Mats of Bars in top slab.

Top Mat - Six 20 M bars evenly spaced (Long Direction)

Bottom Mat - 15 M bars at 200 mm centres each way.

Eight extra 15 M bars around each roof access opening.

Minimum cover over reinforcing steel - 25 mm.

Weight: Top Slab 13,910 kg
Tank Section 21,700 kg
Total 35,610 kg

Actual Capacity: 18,785 Litres Per Vertical Metre.
24,700 Litres to Underside of Roof Slab.
20,000 Litres to Invert of Outlet

NOTES

1. Large 685 mm diameter roof access openings facilitate tank and filter maintenance. Please note that each cover weighs approximately 125 kg and must be handled only with suitable mechanical lifting equipment. Access extensions may be required to meet Ontario Building Code requirements. See section for available options.
2. Fibrous mastic sealant ensures a watertight seal. Primer and Mastic Band are supplied with each tank for application to the external surface of the tank over the joint between the tank section and the top slab. This band is to be applied by the installing contractor.
3. Flexible watertight inlet/outlet pipe connector in each end wall accommodates 100 mm diameter PVC pipe. Size and position of inlet and outlet void can be modified at customer's request. Consult with the factory as to how this will affect the liquid capacity of this tank.
4. Inlet baffle is 100 mm PVC 'TY' fitting. It is supplied loose and meant to be cemented by the contractor to the inlet pipe.
5. NSF certified effluent filter for flow rates up to 38,000 litres per day. Note that the Ontario Building Code requires an effluent filter be accessible at grade. See Access Riser section for available options.
6. Stainless steel bracket supports effluent filter firmly in position to prevent damage or dislocation during pumping and maintenance operations.
7. 150 mm diameter partition flow throughs in four places evenly spaced across the partition.
8. The partition is cast monolithically with the walls and horizontal slab of each section.
9. Bottom section lifting points four places.

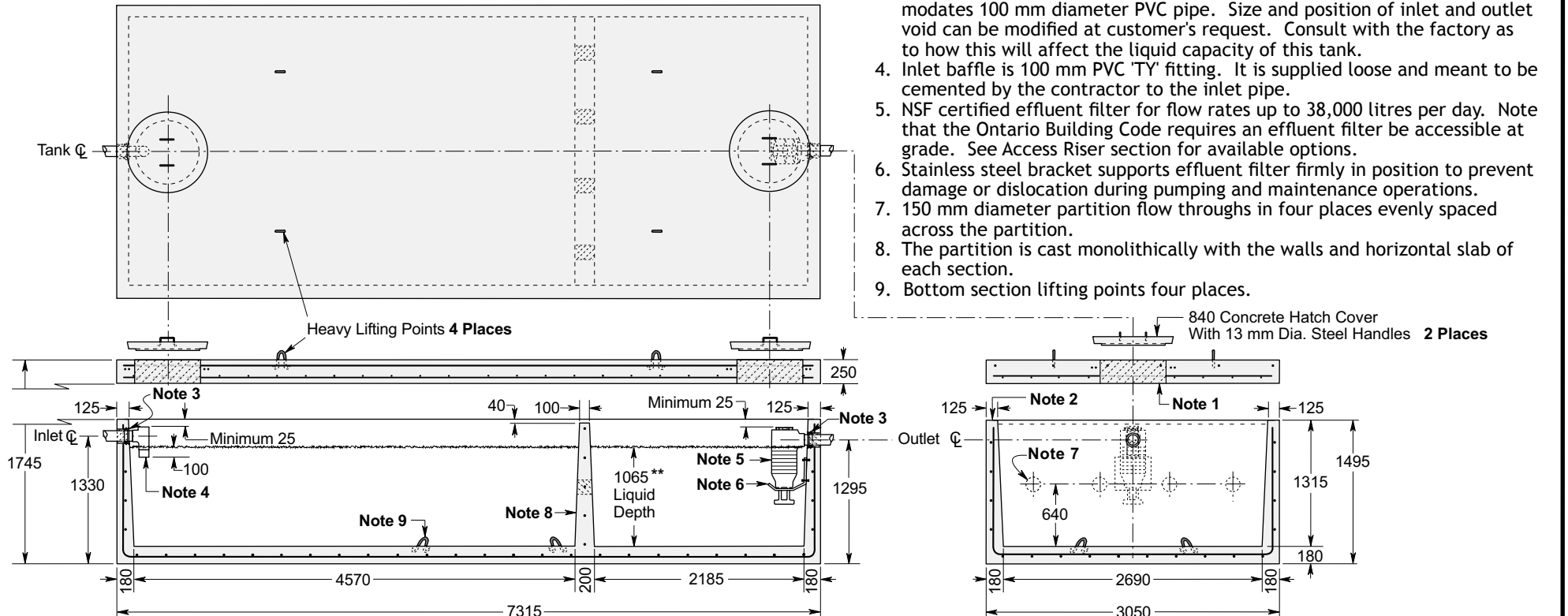

Dimensions in mm
N.T.S.

*Product designed for a Maximum 2 Metre burial over the top slab in firm soil away from any area of vehicular traffic.

**NOTE: While this tank conforms to the requirements of CSA-B66 for a septic tank the working liquid depth is less than the 1200mm required by the OBC and should be used only where rock of high ground water levels exist. OBC 8.2.2.3 (8). For recommended installation procedures refer to Wilkinson