

100,000 LITRE CONCRETE WATER HOLDING TANK MODEL H100S

CONSTRUCTION DETAILS:

Concrete: 35 MPa at 28 Days, 5 to 8% Air Entrainment.

Reinforcing: Designed for a maximum 1.2 metre burial over the top slab in firm soil.
Optional reinforcing for CHBDC vehicular loading available upon request.

WEIGHT: Top Section - 38,750 kg
Bottom Section - 38,750 kg

CAPACITY: Per Vertical Metre - 24,917 Litres
To Underside of Roof Slab - 100,168 Litres

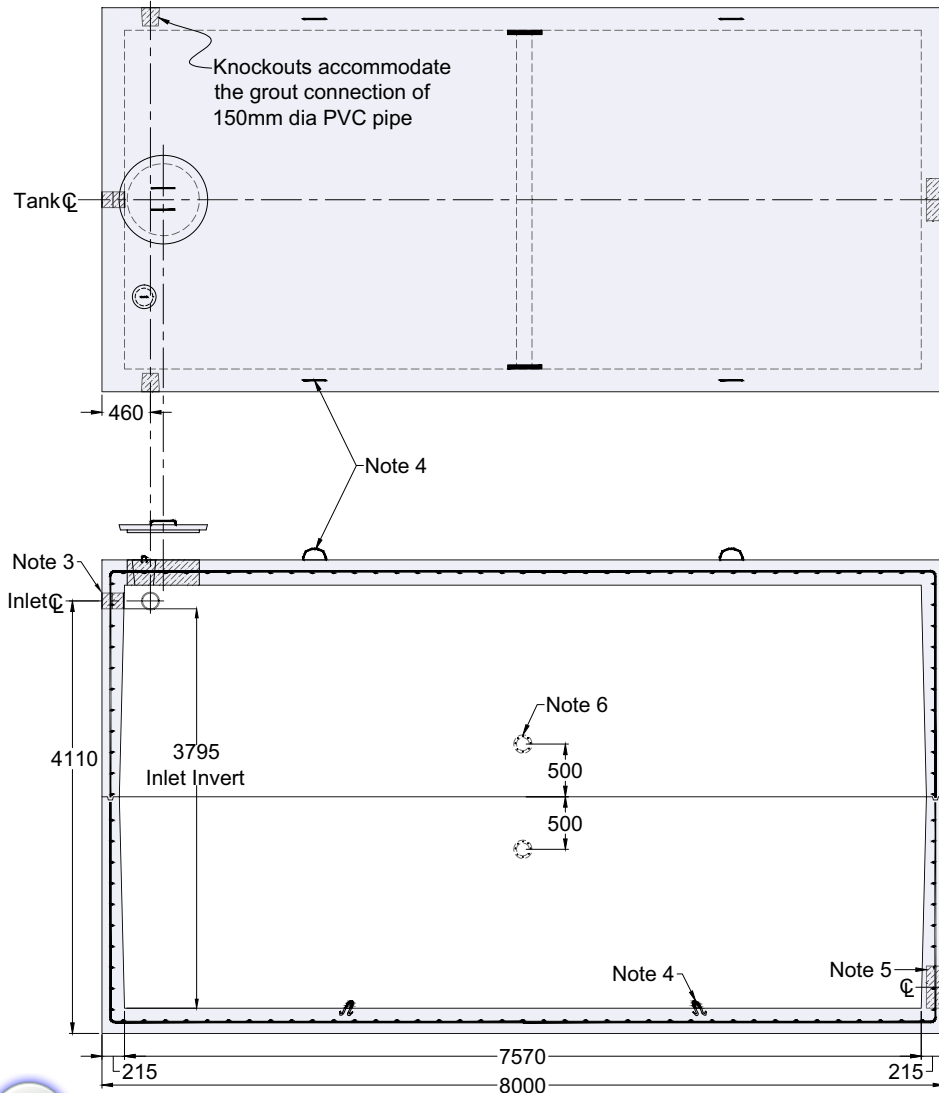

NOTES:

1. Large 685 mm diameter roof access openings facilitate tank maintenance. Unless otherwise specified when ordered this tank will be shipped with 840 mm diameter concrete roof access cover only. Please see [Access Riser](#) section for available riser & hatch options.
2. Close tolerance of tongue & groove joint and fibrous mastic sealant ensures a solid structural & watertight seal. Primer & Mastic Band are supplied with each tank for application to the external surface of the tank over the joint between sections. All sealant is to be applied by the installing contractor.
3. Flexible watertight inlet pipe connector to accommodate 150 mm diameter PVC pipe. Size and location of connections are customizable.
4. Top & bottom section lifting points four places.
5. Knockout suitable to accommodate a flexible, watertight pipe connectoin for 250, 275 or 300 mm diameter PVC pipe.
6. 150mm dia galvanized steel pipe Cross Beams (Stainless Steel Optional).

Some Available Options:

- Aluminum ladder rungs to the floor. Consult with the factory as to how this will effect the size and location of the access opening.
- Mechanical connection of the tank sections to enhance water tightness and resistance to frost heave.

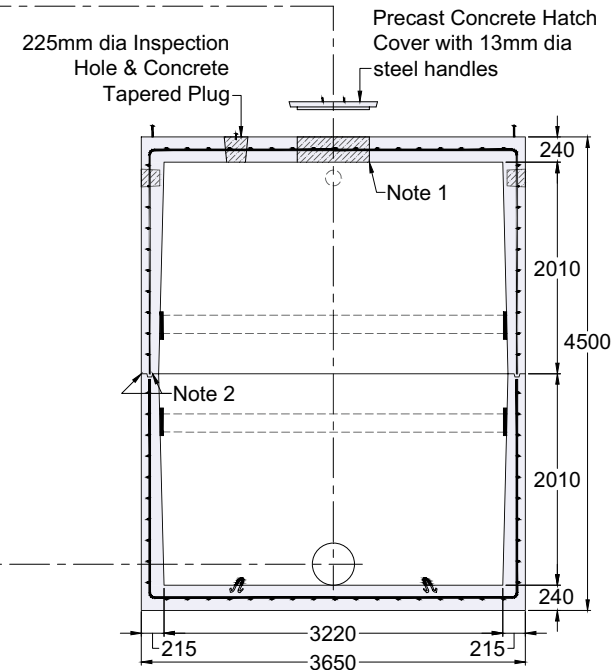

Dimensions in mm
N.T.S.

*Product designed for a **Maximum 1.2 Metre** burial over the top slab in firm soil away from any area of vehicular traffic.

For recommended installation procedures refer to Wilkinson [Installation Guidelines](#).

WARNING! IMPROPER INSTALLATION ESPECIALLY IN UNSTABLE SOIL CAN RESULT IN THE STRUCTURAL FAILURE OF THIS PRODUCT

November 15, 2021